

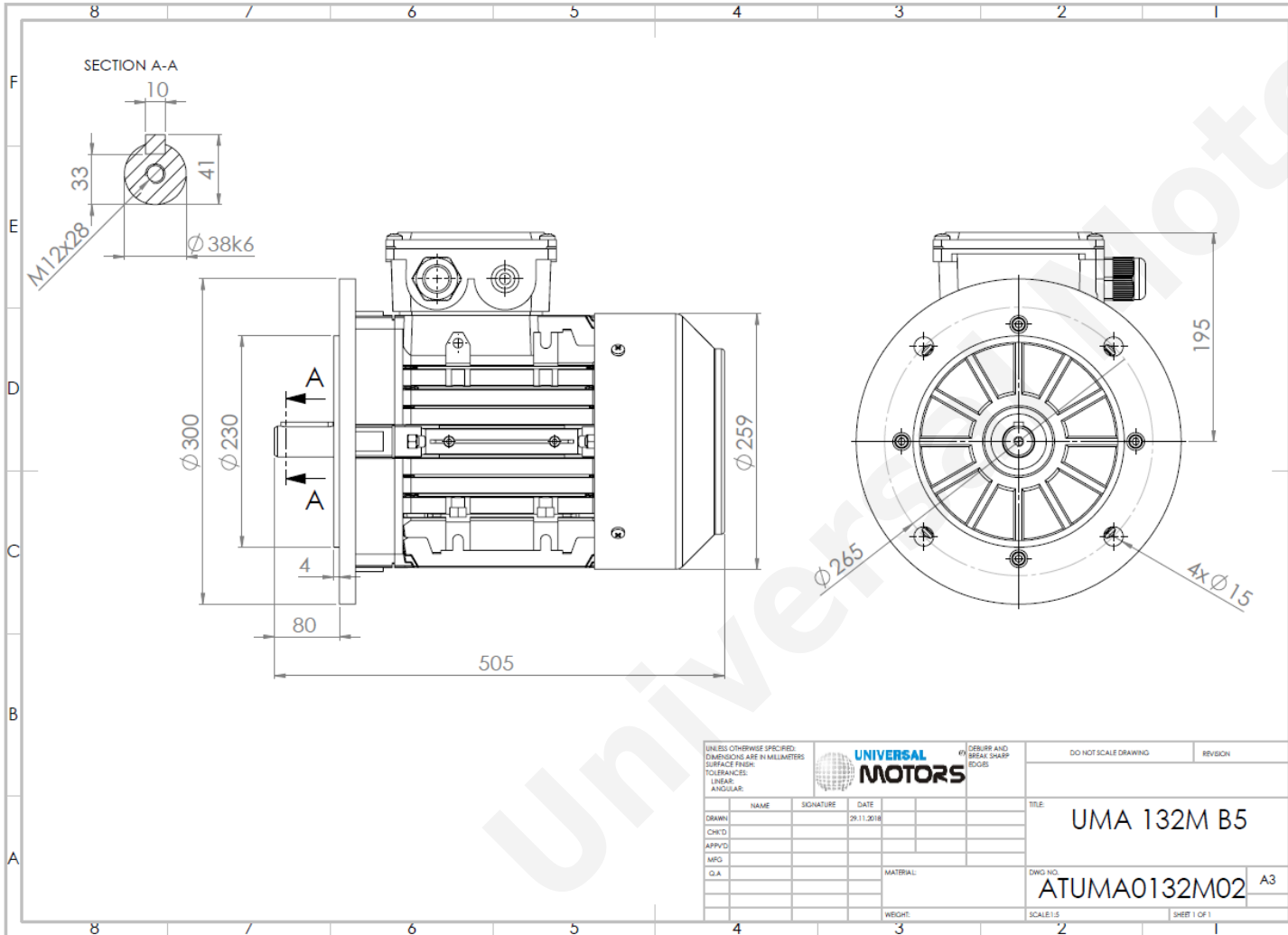

# TECHNICAL DATA

Three Phase Electric Motors - Aluminum Frame  
 UM2A 132M2-2  
 11 kW / 15 Cv  
 2930 RPM



Motor type:	<b>UM2A 132M2-2</b>
Output:	<b>11 kW / 15 Cv</b>
Speed (min <sup>-1</sup> ):	<b>2930 RPM</b>
Frequency:	<b>50 Hz</b>
Voltage:	<b>400 V</b>
Current:	<b>19.7 A</b>
Power factor (Cos Ø):	<b>0.90</b>
Poles:	<b>2</b>
Insulation class:	<b>F</b>
Temperature rise Class:	<b>B</b>
Efficiency 50%:	<b>88.7 %</b>
Efficiency 75%:	<b>89.6 %</b>
Efficiency 100%:	<b>89.4 %</b>
Torque:	<b>35.8 N.m</b>
Tstarting/Tnominal:	<b>4.0</b>
Istarting/Inominal:	<b>12.7</b>
Tmaximum/Tnominal:	<b>3.9</b>
Noise:	<b>83 Db(A)</b>
Weight:	<b>58.5 Kg</b>
Brake AC:	<b>AC7</b>
Torque Brake DC:	<b>80 N.m</b>
Bearing DE:	<b>6308 2Z</b>
Bearing NDE:	<b>6208 2Z</b>
Torque Brake AC:	<b>90 N.m</b>
Brake DC:	<b>REB-05-16</b>

UNLESS OTHERWISE SPECIFIED, DIMENSIONS ARE IN MILLIMETERS			UNIVERSAL MOTORS		DEBURR AND BREAK SHARP EDGES		DO NOT SCALE DRAWING		REVISION	
SURFACE FINISH:										
TOLERANCES:										
LINEAR:										
ANGULAR:										
DRAWN	NAME	SIGNATURE	DATE	TITLE: <b>UMA 132M B5</b>		MATERIAL:		DWG. NO. <b>ATUMA0132M02</b>		A3
CHK'D			29.11.2016			WEIGHT:		SCALE: 1:5		SHEET 1 OF 1
APP'VD										
MFG										
Q.A.										

Regime - S1

Altitude - 1000m

Environment Temperature - 40°C

## CONTACTS:

UNIVERSAL MOTORS Tel: +351 252 299 080  
 Rua de São Brás, 745 Fax: +351 252 299 089  
 4480-782 VILA DO CONDE Mail: [geral@universalmotors.pt](mailto:geral@universalmotors.pt)

\* References applied only in the UK